

A8型 A9型

使用手册

Instruction Manual

使用前请阅读此手册
Please read this manual before operation

使用前的注意事项
CARE BEFORE USE

发球机及集球网的各部位名称	第 2 页
Components name of the table tennis robot and ball collecting net	page 2
发球机的安装及摆放位置	第 3 页
Installation and position of robot	page 3
使用电源	第 6 页
What power supply to use	page 6

发球机的功能介绍
INTRODUCTION TO
FUNCTIONS OF THE
TABLE TENNIS ROBOT

发球形式	第 6 页
Ways to serve the ball	page 6
速度调节	第 7 页
Speed modulation	page 7
频率调节	第 7 页
Frequency modulation	page 7
出球落点选择	第 8 页
Selecting the landing spot	page 8
出球次数选择	第 9 页
Selecting number of balls	page 9
长短球选择	第 9 页
Selecting long and short balls	page 9
旋转选择	第 10 页
How to select spin	page 10
弧度调节	第 10 页
Loop modulation	page 10

注意事项与保养
CAUTIONS AND
MAINTENANCE

储球器的容量	第 10 页
Capacity of the ball Container	page 10
发球机的保养	第 11 页
How to maintain the table tennis robot	Page 11
故障的排除方法	第 13 页
Trouble shooting	Page 13
安全使用注意事项	第 14 页
Safe utilization and the regulations	Page 14

发球机及集球网的各部位名称
Components name of the table tennis robot and ball collecting net

A8

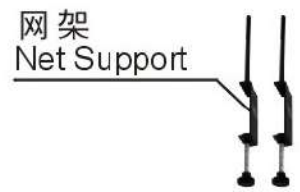

A9



发球机的安装及摆放位置 Installation and position of robot

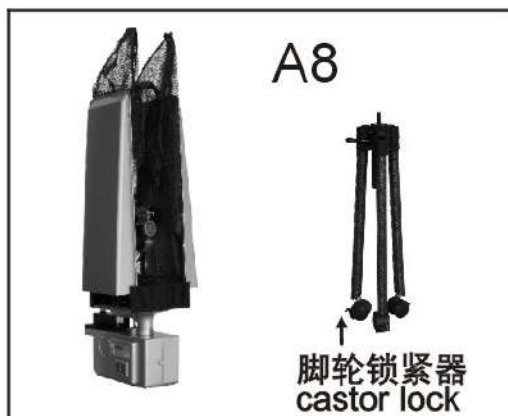

1、将机身平放，脚架固定轴的扁位对准机身上的锁紧旋钮方向插入孔内，锁紧旋钮（图1）。立起机身，将保险环调至可固定脚架位置，锁紧保险环调节手柄（图2）。移动时应把脚轮锁紧器打开。

Lay down the machine body, aim and insert the pin of tripod into the hole, and then lock it up with the knob (Picture 1). Stand up the machine body, rotate the safety ring to the position where to fix the tripod, tighten the adjustable grip (Picture 2). Please open the castor lock while moving the machine.

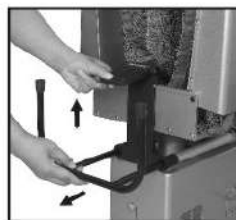

1、将定位夹沿水平方向拉出，活动卡板往上打开。插入球台底线分中位置固定。

Pull out the U-shaped support horizontally, open up the moveable clamp, insert and fix the robot to the baseline of the table (set up in the middle area).

发球机的安装及摆放位置 Installation and position of robot



- 2、将集球网的锁扣打开。
Open the lock buckles of the ball collecting net.

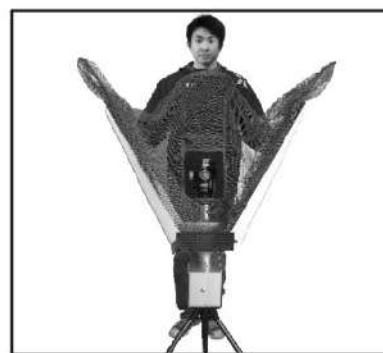

- 3、将集球网向两边分开。
Spread out the ball collecting net with both sides.

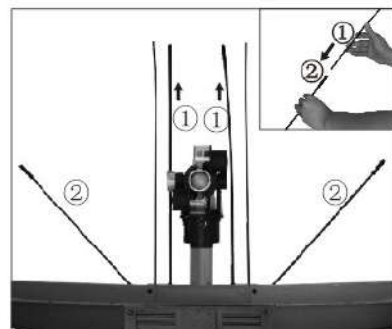

- 4、①号圆杆拔出插入②号圆管，
对住卡口定位。
Pull out the round bar ①,
And then insert it into the hole
of round bar ② .



- 5、集球网安装完成。
Completed installation
of ball collecting net.

发球机的安装及摆放位置 Installation and position of robot

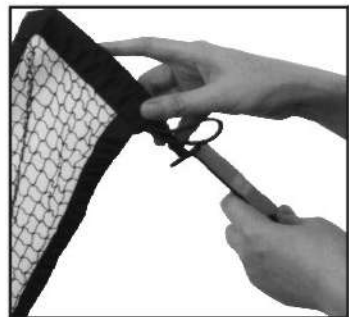

6、将集球网两侧的尾端套进网架上。

Put both end sleeves of the ball collecting net on the net supports.

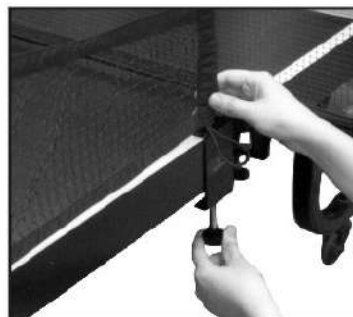

7、网架分别夹在球台近球网的两侧。

Clamp the net support onto both sides of table (close to the net).

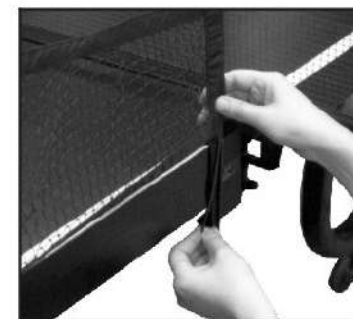

8、橡皮筋扣在网架的侧边。

And the rubber rings are to be buckled to the outsides of the net support.



9、全部安装完毕展示图。

The presenting picture of a completed installation.



10、训练结束，将集球网按原来程序收叠，将锁扣扣好，搬放在任意位置，移动发球机与装拆集球网，请小心轻放。

After finishing the practice, fold back the ball collecting net, buckle it up, and move it to any suitable place, be careful when connecting and disconnecting the ball collecting net.

使用电源 What power supply to use



发球机的适用电源按标贴注明的电压范围内使用。使用发球机时把电源开关拨在开(ON)的位置,使用完毕请关闭电源(OFF)并把电源插头拔开。

The applicable power supply for this robot is indicated on the label. Turn on the switch when using robot. Turn off the switch and unplug the power cord after use.

发球形式 Ways to serve the ball

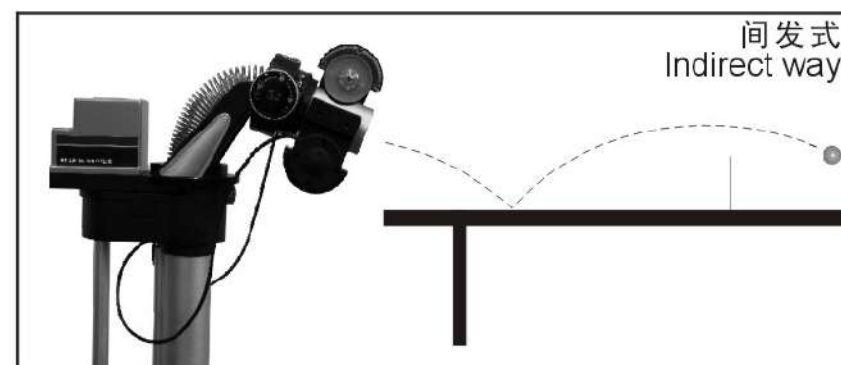
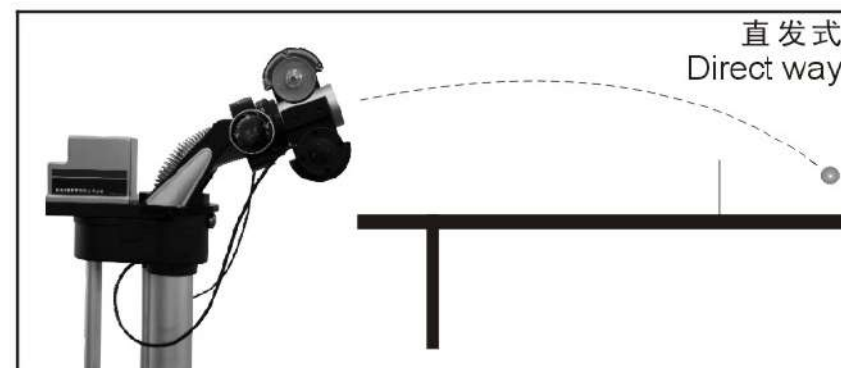

发球机的发球形式分为直发式和间发式,直发式发出的球速度和旋转都比间发式稍强,调整时通过弧度调节旋钮进行。

The ways of serving the balls consists in the direct way and indirect way. The speed and spin of the former will be stronger than those of the latter. They may be adjusted with the loop adjustment knob.

速度调节 Speed modulation

可在暂停状态或工作状态时调节。当发球机接通电源时，控制盒上档位闪烁，如显示的档位合适，可直接按开始键工作。如需重新选择可按“ \ominus ”键减档（减速），按“ \oplus ”键加档（加速），调节好选定的速度档位，再按开始键工作。上、下轮可同时工作，亦可单独工作。发球机由低至高共10级档位。低档最慢，高档最快，速度快慢与乒乓球的旋转强弱基本成正比。如上、下轮档位接近时，所发出的球则基本没有旋转。控制盒具有暂停或停电记忆功能，下一次开机时仍然保留关机前的设定值。

Ball speed can be adjusted in the “Working” or “Stand by” condition of the robot. The stage-level light on the control box will flash when the power of the robot is on. If the stage doesn't need to be changed, press the start key directly to play. Otherwise, adjust the stage level by pressing the “Increase” or “Decrease” key. There are totally 10 stages from lowest to highest level. The top wheel and bottom wheel can work at the same time or work independently. The higher the stage being selected, the faster the ball speed will become. Basically the speed of the ball is proportional to the strength of the spin. If the stages of two wheels are close enough, the ball that has been produced is nearly no spinning. The control box also has a memory function that memorize the current setting which is capable to play with the same setting as next time you start.



频率调节 Frequency modulation

与速度调节方法相同，也是通过“ \oplus ”键和“ \ominus ”键调节，由低至高共分10级。低档时出球频率最慢（约25球/分钟），高档时最快（约95球/分钟）。

With the same modulation method as speed's, the frequency can also be adjusted by pressing the “Increase” or “Decrease” key with totally 10 stage level. The lowest stage of frequency is about 25 balls per minute and the highest stage is about 95 balls per minute.

出球落点选择 Selecting the landing spot

在发球机暂停状态下选择, 发球机有定点、标准左右两点及任意多点组合等多种出球落点选择, 在控制盒上有11个按键, 同时也代表了球落在球台上的11个位置, 控制盒上的蓝色部份则代表球台; 选择时, 先按出球落点选择键, 此时1~11按键的指示灯是灭的, 当选择某一位置时, 此位置的指示灯就会亮, 按开始键, 发球机开始工作。例如: 选择定点球, 要求9号位置落球: 那就按上述步骤按一次9号键, 选择两点球: 11号位出3个球, 1号位出两个球, 那就按上述步骤连续按11号键3次, 连续按1号键2次, 组合球也是同一原理, 在11个位置范围内, 任意在哪个位置按多少次, 它就在那个位置上出多少次球, 反复循环同时自动记忆, 下次开机时仍是这种设定, 如需改变, 则按照以上步骤重新设定。

The landing spot should be selected in the “stand by” condition of robot. The robot can perform three main kinds of serving style: fixed course, standard alternative course and random course. There are 11 digit keys located at the bottom portion of control box. Those keys indicate the 11 positions of the table which the blue part indicates the whole table area on the play side. To select the landing spot of the ball, first press the “Select the landing spot” key, all indicator lights of 1-11 position will be turned off at this point. Now we can press either one of the position, then the light of the corresponding position being turned on. Start the robot to play after finishing the selection. For example, to play fixed course with the landing spot at the #9 position, we can press the digit “9” key to start. If we want to play alternative course and the ball will be landing at the # 11 position three times, and at the #3 position twice, we can follow the above procedures, then press the digit “11” key three times and digit “3” key twice. The numbers of ball which land on the same spot depend on how many times you press on the same position key. You can create as many as combination of the serving style. The control box also has a memory function that memorize the current setting which is capable to play with the same setting as next time you start.



出球次数选择 Selecting number of balls

在发球机暂停状态下选择，按确定出球次数键。出球次数在1~999范围内任意选择，按数字显示窗下的“个”“拾”“佰”位键。显示窗内对应的数字灯0~9加一循环计数，按开始键，发球机开始定量出球，显示窗内数字自动减一计数，当减到0时发球机暂停工作，数字灯全灭。重新设定可按以上方法操作。重复已设定的上一次的数值，按确定出球次数键，然后按开始键工作。不再定量出球（也就是无限量出球）则直接按开始键工作。

To select the amount of ball to play during the robot in “stand by” condition. After the selection, press the “Enter” to input the number. The number of balls can be selected at the range from 1 to 999. There are totally 10 numbers which from 0-9 in each ones, tens and hundreds place. The number will increase by one digit every time pressing the selection key. Once the amount has been entered, the digital display shows that the number decrease one by one automatically. The robot will stop right away when the numbers reach to 0. To set the “Infinite” balls, start the robot directly without inputting any number.

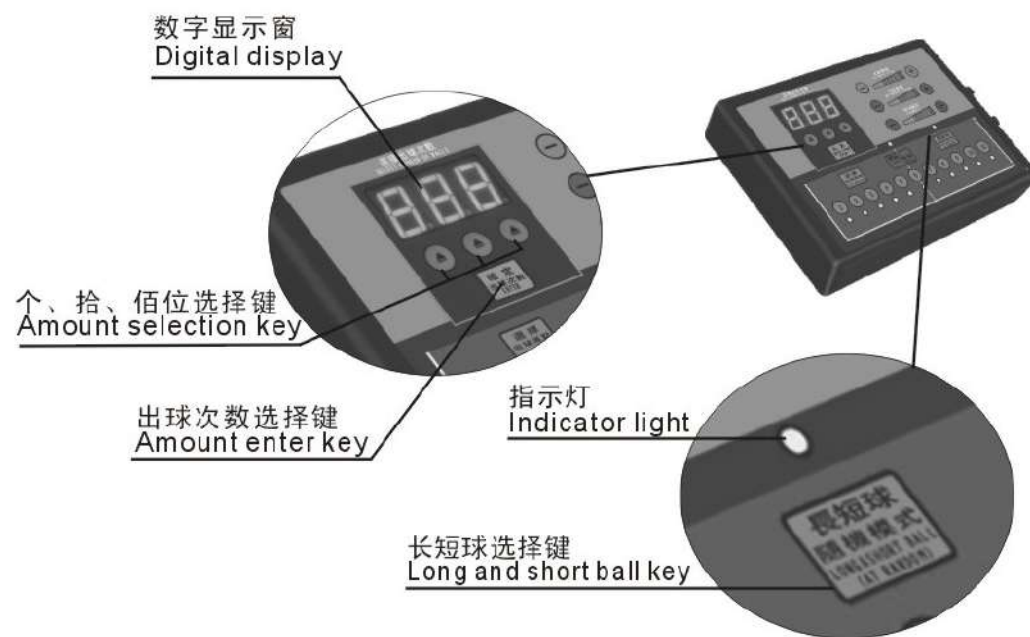

长短球选择(随机模式) Selecting long and short balls (at random)

长短球可在发球机工作或暂停状态时选择。当按长短球选择键时，指示灯亮表示发球机按随机设定的程序发长短球；再按长短球选择键时，指示灯灭，表示发球机按标准落点出球。

The long and short ball mode can be selected in the “Working” or “Stand by” condition of the robot. After the long and short ball key has been pressed, the indicator light indicates that the ball become long and short randomly. Otherwise, if the key being pressed again, the indicator light will turn off. and the ball back to original standard serving style.



图1
Picture1

旋转选择 How to select spin

旋转由调节上、下轮速度和左右调节机头方向来选择，可发9种旋转球：包括上旋、下旋、不旋（由调节上、下轮速度来控制）、左侧旋、右侧旋、左侧上旋、左侧下旋、右侧上旋、右侧下旋（如图1）。

Spin can be selected by adjusting both the speed of top-wheel and bottom-wheel and by rotating the motor head of robot. There are totally 9 different spins you can choose from: top spin, under spin, no spin (produced by varying the speed of top and bottom wheel), left side spin, right side spin, left-side top spin, left-side under spin, right-side top spin and right-side under spin (Picture1).



图2
Picture2

弧度调节 Loop modulation

调整出球弧度的高低时，首先用左手松开弧度锁紧旋钮，右手握住弧度调节旋钮任意调整，达到自己所需的弧度后，将弧度锁紧旋钮锁紧（如图2）。

When modulating the loop of the serve, loosen the loop lock knob with your left hand, while adjusting the loop modulation wheel with your right hand. When achieving your desired loop, lock the knob (Picture2).



图3
Picture3

储球器的容量 Capacity of the Ball Container

可装40mm球约100个。不能将其它杂物也倒入储球器内，否则会损坏机内零件，并影响发球机的正常工作（如图3）。

The ball container can be loaded with about 100 balls in 40mm size. Except the TT balls, do not put any other objects into the ball container, otherwise, the internal parts could be damaged, which affecting the normal operation of robot (Picture3).

发球机的保养

How to maintain the table tennis robot

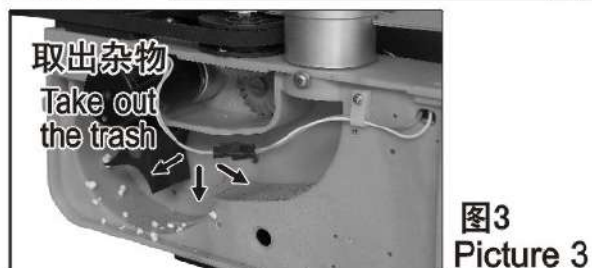

电器部份：本产品的电器部分主要由主机线路板及控制盒组成，是发球机的指挥中心，所以尽可能避免受强烈震荡，控制盒一定要按要求插在球台边的支架上，以免摔坏。任何液体都不能洒在上面，防止漏电及损坏内部的电子元件。

机械部份：发球机的机械部份主要集中在输送球机构方面，特别注意的是除了乒乓球以外，任何杂物不能放入储球器内，否则杂物会卡住发球机的输送轮，造成不出球甚至损坏发球机，如果发现杂物，先松开1、2号旋钮，打开外壳，拆下透明保护板，将杂物取出即可正常工作（如图1-3）。储球器内拨条使用长时间后，需检查是否有螺丝松动或拨条断裂等，以防止有下球不顺畅故障发生（如图4）。

Electric component: Electric component in this product consists mainly of the base machine's circuit boards and the control box, which is the command center of the table tennis robot. Therefore, it should avoid any strong oscillation as much as possible. The control box must be inserted to the support at the side of the table to avoid any dropping and breaking. Never spread any liquid to its surface, in order to prevent electric leakage and/or damage to its internal electronic units.

Mechanical component: Mechanical component in this product is concentrated mainly on the mechanism for ball delivery. Please do not put any other objects into the ball container except for the standard table tennis ball. Otherwise, the delivery wheel would be blocked by those objects, and result in no ball delivery and even make damage to the robot. To take out the foreign objects, first of all loosen the Knob 1 and Knob 2, open the movable door, and remove the transparent guard plate. After you take out the trash, the robot will be back to normal operation. (Picture 1-3). Please check for loose screw or broken poke bar after you have used a robot for a long time. This should prevent any blockage issue inside the robot (Picture 4).

发球机的保养 How to maintain the table tennis robot

正常情况下使用，上、下轮（摩擦轮）能用5000小时以上，使用时间过长则需要更换新的。更换时，首先松开保护罩，用螺丝批取下摩擦轮的螺丝，顺时针锁紧，逆时针松开。

发球机应保持清洁，上、下轮（摩擦轮）使用时间长会有污垢，需用湿布抹掉，以保证出球的质量，另外各部位的旋钮在使用过程中，调整力度要适当，不能粗暴强力操作，防止损坏内部零件。使用及运输时需防止对发球机的强力撞击或震荡，练习结束后，请关机并拨开电源插头。

Under normal conditions, the top and bottom wheel (friction wheel) can work for 5000 hours or longer. However, the friction wheel should be replaced after over time use. When replacing, first of all, loosen the protective cover and take out the screw at the friction wheel with a screwdriver, which is to be tightened clockwise and to be loosened counter-clockwise.

The table tennis robot should be kept clean. There would be some dirt on the surface of top and bottom wheel (friction wheel). But such dirt can be wiped off with a wet rag, so as to ensure a quality shoot of the ball. Suitable strength should be used when turning the regulation knobs at the other places during an operation. Never do it with a rough or shock force, so as to prevent damage to the internal parts. During an operation and/or transportation, protect the table tennis robot against any strong impact or oscillation. Unplug and cut off the power supply when you have finished your exercise.



故障的排除方法 Trouble Shooting

故障 Failure	故障原因 Cause	排除方法 Solution
主机不工作 Machine doesn't work	<ul style="list-style-type: none"> ● 选择的出球次数已出完，处于暂停状态 The selected number of balls has run out and robot is in "stand by" condition. ● 电源线插头与插座接触不良 The plug and socket are not properly contacted ● 控制盒轻触开关未按 The key on the control box is not pressed ● 控制盒因强烈震荡而失灵 The control box doesn't work due to fierce shake ● 超时自动保护功能启动 Self-protecting timeout function has been turned on 	<ul style="list-style-type: none"> ● 按开始键 Press the "start" key ● 检查电源插座 Check the electric socket ● 按下开关到显示窗内数字亮 Press the switch until the number display ● 更换控制盒 Replace the control box ● 按开始键 press "Start" button
主机工作但不出球 Machine works, but does not release the table tennis balls	<ul style="list-style-type: none"> ● 储球器内拨条松动 The poke bar in ball container is lax ● 有杂物堵塞输球管道 The ball duct is jammed by foreign objects ● 储球器内的乒乓球数量太少 The amount of balls in the container are not enough 	<ul style="list-style-type: none"> ● 锁紧拨条 Fasten the poke bar ● 清除杂物(见第11页中的机械部份) Clear away the foreign objects(see page 11) ● 保持在50~100个球 The amount should be kept at 50-100 balls.
速度、频率失调 Speed and frequency cannot be adjusted	<ul style="list-style-type: none"> ● 控制盒内零件暂时失灵 The parts in control box do not work temporarily ● 连接电机的电线松脱 The cable connecting to motor is loosen ● 控制盒轻触按键失灵 The pressing key on the control box do not work properly. 	<ul style="list-style-type: none"> ● 断开电源5秒后启动 Start up again after shut-off for 5 seconds ● 按原样连接 Connect it with the original method ● 更换控制盒表面的薄膜开关 Replace the thin-film switch on the surface of control box
落点不稳定 Landing spot is unstable	<ul style="list-style-type: none"> ● 上、下轮(摩擦轮)因长时间使用积污垢或磨损 There would be dirt and wear on the top-wheel and bottom-wheel after a long time of operation ● 选择了长短球功能 Long and short ball mode has been selected. 	<ul style="list-style-type: none"> ● 清洁或更换 Clean or replace the friction wheel ● 取消长短球功能 Cancel the long and short ball mode.

本公司有权未经事先声明对本手册中的产品描述进行改进。

The company has the right to amend the description of products in this manual without any notice in advance.

安全使用注意事项 Safe utilization and the regulations

1. 使用前请仔细阅读使用手册，并按使用手册指示操作发球机。
2. 儿童需在成人指导下使用。
3. 室外使用时，须避免在风沙和雨雪环境下进行。
4. 移动发球机与装拆集球网，请小心轻放。
5. 发球机工作时，请勿开启外壳、触及摩擦轮和储球器内拨条。
6. 发球机工作时，请勿与出球口近距离正面接触，防止乒乓球射出伤及人体。
7. 发球机工作时，如闻到异味或冒烟等非正常现象，请立即停机及拔开电源插头，请具有维修资格人员检修。
8. 发球机在使用过程中某些部位可能会产生温度，请小心触摸以免烫伤。
9. 使用结束，请关机并拔开电源插头。

1. Please read the instruction manual carefully before using the robot, and follow the instruction to operate the robot.
2. Instructive advice should be given when machine used by children.
3. Avoid the windy and rainy day for the outdoor use.
4. Be careful when connecting and disconnecting the ball collecting net.
5. When the robot is operating, please don't open the movable door and touch the top and bottom wheel, poke bar either.
6. When the robot is operating, please keep away from the shooting head of the robot to avoid the ball harm the body.
7. When the robot is operating, if you found something abnormal, such as some smoke come from the machine, please stop the robot and unplug it immediately. Repair or service must be performed by a qualified repair person.
8. Some places of robot will heat up during the operation. Please pay attention to avoid burning yourself.
9. Turn the power switch off and unplug the robot after use.